

Extend



Extend series

TYPY / TYPES / TYPE			
ŘEZNÁ ŠÍŘKA, ŘEZNÁ VÝŠKA / CUTTING WIDTH, CUTTING HEIGHT / SCHNITTWEITE, SCHNITTHÖHE			
	STANDARD	OPTIONAL	
Extend 520	520.520 41 x 1,3 x 6280 mm	700.520 41 x 1,3 x 6640 mm	4,0 kW / 5,5 kW
Extend 620	620.620 41 x 1,3 x 6940 mm	800.620 41 x 1,3 x 7300 mm	4,0 kW / 5,5 kW
Extend 720	720.720 54 x 1,6 x 8200 mm	900.720 54 x 1,6 x 8560 mm	5,5 kW / 7,5 kW
Extend 820	820.820 54 x 1,6 x 8920 mm	1000.820 54 x 1,6 x 9280 mm	7,5 kW / 9,0 kW
Extend 1120	1120.1120 67 x 1,6 x 11200 mm	1320.1120 67 x 1,6 x 11520 mm	11 kW / 15 kW
Extend 1320	1320.1320 67 x 1,6 x 12160 mm	1600.1320 67 x 1,6 x 12710 mm	11 kW / 15 kW
Extend 1520	1520.1520 80 x 1,6 x 11200 mm	1800.1520 80 x 1,6 x 11760 mm	11 kW / 15 kW
Extend 2020	2020.2020 80 x 1,6 x 13200 mm		18,5 kW



Extend SVHT

ŘEZNÁ ŠÍŘKA, ŘEZNÁ VÝŠKA / CUTTING WIDTH, CUTTING HEIGHT / SCHNITTWEITE, SCHNITTHÖHE		
Extend 1600.820	Horizontal cut (without vice) 1600 x 1600 x 820 mm	Vertical cut (with vice) 800 x 800 mm



KOMPLETNÍ SESTAVY S POHÁNĚNÝMI DOPRAVNÍKY, PŘÍČNÝMI PODAVAČI A DORAZY S ODMĚŘOVÁNÍM DĚLEK
COMPLETE HANDLING SYSTEMS WITH POWERED CONVEYORS, CROSS-FEEDERS AND LENGTH STOPS
KOMPLETTE ANLAGEN MIT ANGETRIEBENEN ROLLENBAHNEN, QUERFÖRDEREINHEITEN UND LÄNGENANSCHLAGEN

AL



AL 400

60° L	96	100 x 55	45 x 125	85 x 85
0° jaws ahead	120	220 x 25	90 x 120	110 x 110
0° jaws back	90	285 x 70	285 x 70	70 x 70
45° R	120	150 x 40	65 x 125	100 x 100
60° R	96	100 x 55	45 x 125	85 x 85

Extend 700.520 A 1500/2500

0°	520	700 x 520	700 x 520	520 x 520
4 kW	6640 x 41 x 1,3 mm			

Extend 800.620 A 1500/2500

0°	620	800 x 620	800 x 620	620 x 620
4 kW (5,5 kW)	7300 x 41 x 1,3 mm			

Extend 900.720 A 1500/2500

0°	720	900 x 720	900 x 720	720 x 720
5,5 kW (7,5 kW)	8560 x 54 x 1,6 mm			

Extend 1000.820 A 1500/2500

0°	820	1000 x 820	1000 x 820	820 x 820
7,5 kW (9 kW)	9280 x 50 x 1,6 mm			

AL 500

60° L	120	120 x 70	55 x 170	115 x 115
0° jaws ahead	170	265 x 25	90 x 175	150 x 150
0° jaws back	135	395 x 70	375 x 95	95 x 95
45° R	150	180 x 50	80 x 170	130 x 130
60° R	120	120 x 70	55 x 170	105 x 105

AL 600

60° L	145	155 x 50	40 x 225	125 x 125
0° jaws ahead	205	310 x 50	110 x 210	175 x 175
0° jaws back	170	500 x 50	125 x 455	125 x 125
45° R	180	215 x 50	50 x 225	155 x 155
60° R	145	155 x 50	40 x 225	125 x 125



AL 500 ANC

0°	170	325 x 110	130 x 300	130 x 130
4 kW	300 x 30 x 4 mm			

Deburring



BASIC 200

brush dimensions	200 x 40 mm
speed	2800 min ⁻¹
max. material dimensions	90 x 90 mm
output	1,5 kW

SINGLE 250 S / SINGLE 250 II.

brush dimensions	250 x 55 mm
speed	300 - 2800 min ⁻¹ / 2800/1400 min ⁻¹
max. material dimensions	90 x 90 mm
output	2,2 kW

DUAL 250 S / DUAL 250 II.

brush dimensions	250 x 55 mm
speed	600 - 2800 min ⁻¹ / 2845/1390 min ⁻¹
max. material dimensions	95 x 95 mm
output	2,2 kW
Ø of exhausting tube	80 mm

ORBITAL 250 NS / ORBITAL 250 NII.

brush dimensions	250 x 190 mm
speed	600-2700 min ⁻¹ / 2480/1220 min ⁻¹
max. material dimensions	120 x 120 mm
output	3 kW / 3,1/2,6 kW

Vertical



SV 330 DGH

0°	320	330 x 330	320 x 330	320 x 320
45° R	265	320 x 265	320 x 265	265 x 265
45° L	265	320 x 265	320 x 265	265 x 265
60° R	150	320 x 150	320 x 150	150 x 150
60° L	180	320 x 180	320 x 180	180 x 180

VBS 630

0°	830	830 x 830	830 x 830	830 x 830
5,5 kW	7200 x 54 x 1,3 mm			

System M

M 230 / 330 / 430

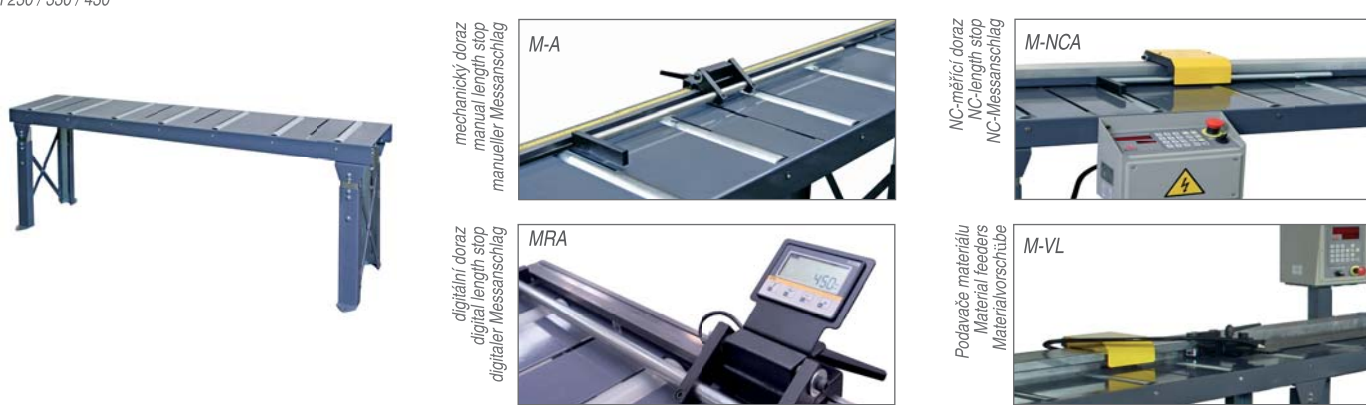

Mechanický doraz / manual length stop / manueller Messanschlag (M-A)
Digitální doraz / digital length stop / digitaler Messanschlag (MRA)
NC-měřicí doraz / NC-length stop / NC-Messanschlag (M-NCA)
Pohonová materiálu / Material feeders / Materialvorschübe (M-VL)

System T

T 440 / 540 / 640



Mechanický doraz / manual length stop / manueller Messanschlag (T-A)
Digitální doraz / digital length stop / digitaler Messanschlag (T-RA)

System X/XP

XXP 450 / 550 / 650 / 750 / 850 / 950 / 1050 / 1150

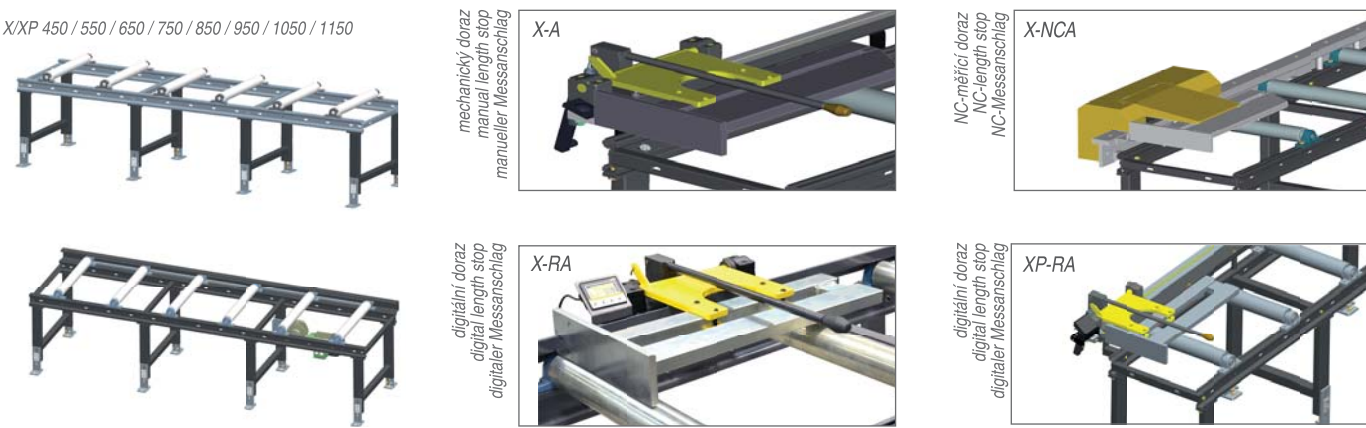

Mechanický doraz / manual length stop / manueller Messanschlag (X-A)
Digitální doraz / digital length stop / digitaler Messanschlag (X-RA)
NC-měřicí doraz / NC-length stop / NC-Messanschlag (X-NCA)
Digitální doraz / digital length stop / digitaler Messanschlag (XP-RA)

Podavače materiálu / Material feeders / Materialvorschübe



XBV
XVL
XVZ

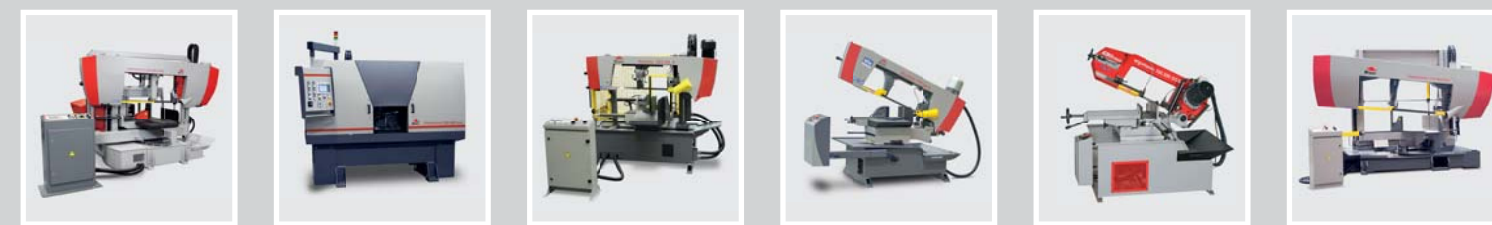

Výrobní program
Product range
Programmübersicht



BOMAR
VÁS OBCHODNÍ ZÁSTUPCE
YOUR BOMAR PARTNER
IHR BOMAR PARTNER
WWW.BOMAR.CZ

BOMAR